

NatureClean's SM-500 by Southern Manufacturing

The NatureClean's aerobic treatment systems provide a competitively priced and environmentally safe method to treat household wastewater. They are intended for use in areas where sewers are not available and conventional septic tanks are not suitable due to soil or site constraints. NatureClean's primary single home systems is a three-chamber Aerobic Treatment Unit (ATU), made by Southern Manufacturing Company. The SM-500 has met the NSF requirements for noise levels (less than 60 dbA at a distance of 20 feet) that successfully met the performance requirements established by NSF/ANSI Standard 40 Class I effluent. As well as the NSF threshold odor requirements.



A typical residential treatment unit is approximately 6 feet wide by 12 feet long by 6 feet deep. After installation it is completely buried and covered with grass or

landscaping. Manholes allow easy access for service or maintenance without the need to disturb yard or landscaping areas. This system can also be totally above ground to be used in areas where there is very high water table or rocky ground, or steep slopes



After processing, the treated effluent is pumped into a network of shallow (6" to 10" deep) drip irrigation lines that are specially fabricated by [GEOFLOW](#) to prevent clogging, root intrusion and microbial growth. A drip field under construction is shown to the left. Because of both pressurization and shallow depth, drip lines can be installed in areas of shallow bedrock, rocky soils, around trees and in a variety of situations where a conventional septic drain field could not be constructed.

Southern Aerobic Systems

Southern Manufacturing Company is a family owned business with over 60 years of experience in wastewater treatment spanning three generations. In 2002 Southern developed a state-of-the-art Aerobic Treatment Unit called the SM-500.

The SM-500 system has undergone extensive testing by [Baylor University](#) and the [National Sanitary Foundation](#), where it was proven to remove more than 98% of wastewater contamination and earned the highest standing of Class 1 status.

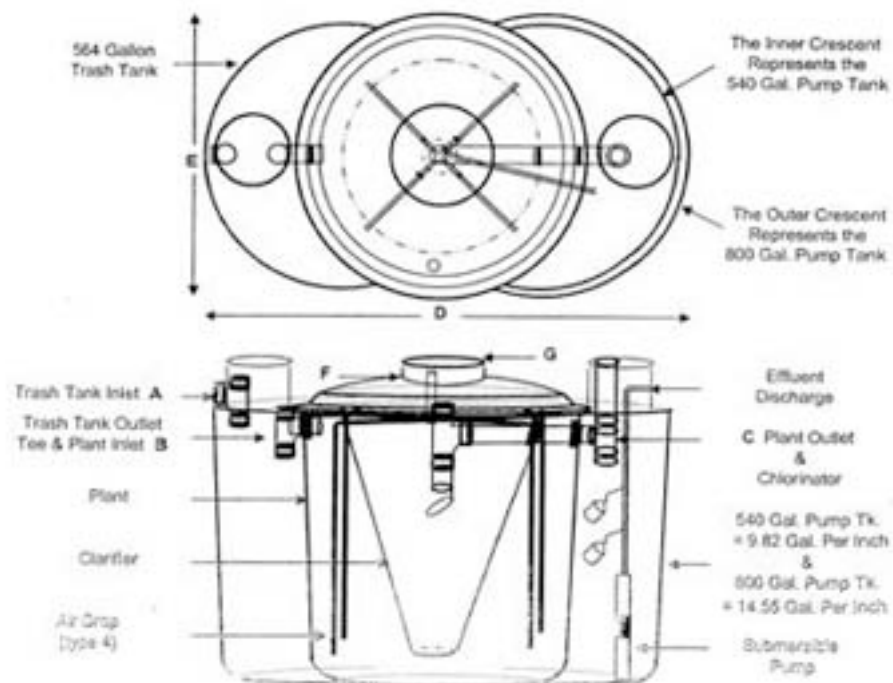

The system consists of a single unit with three compartments: a trash tank, the aerobic chamber, and a storage and pumping chamber. Advantages of the SM500 system over other available aerobic systems include:

1. The SM-500 uses a single, durable fiberglass tank that is highly resistant to damage. Unlike competitors that use multiple treatment tanks, the simplicity of the Southern Manufacturing “all-in-one” tank cuts down on excavator and installation time and eliminates the possibility of misaligned

tanks or leaking underground connections.

2. The SM-500 only weights 1,100 lbs, so unlike many of our competitors who use concrete tanks that can weigh up to 18,000 lbs, our installations are easier and allows us better access to difficult sites, and it costs the client less.
3. The large storage capacity of the SM-500 prevents overloading or incomplete treatment during periods of peak usage.
4. Southern Manufacturing uses the highest quality [Hydromatic pumps](#), [Rhombus control panels](#) and components to provide long life and low maintenance.
5. The SM-500 system automatically self cleans and back flushes, and it has a single, modest reusable effluent filter. Together, this minimizes clogging and reduces the need for maintenance compared to other more complex "filter" or "media" based systems.

All our SM systems are tested and certified by the [National Sanitation Foundation](#)